



HANGING



CLIMBING



WALK/BALANCE



CATALOG COLLECTION	DYNAMICS
DIMENSIONS (L x W x H) in cm	640 x 440 x 330
MAXIMUM CFH	200
IMPACT ATTENUATING SURFACE	min. 61,25 m ² - MAX 71,25 m ²
SUGGESTED AGE OF USE	8+
COMPOSITION	<ul style="list-style-type: none"> - n°9 aluminium Ø127 round poles - n°3 aluminium decks - n°4 metal guardpanels - n°3 HDPE sheet guardpanels - n°1 modular slide - n°1 monkey swing - n°1 spinner - n°1 metal tubular arches bridge - n°1 metal arch climbing - n°1 metal ladder - n°1 perch - n°2 HDPE sheet decorations

SECURITY AREA

740

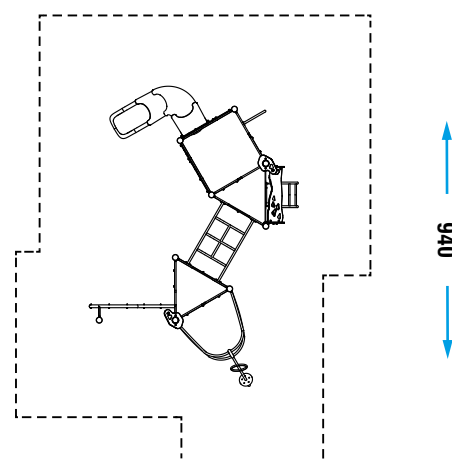

Make a proper security surface according to CFH. Periodic maintenance is mandatory, following manual supplied to customer.