

PRODUCT SHEET
REV 2.1 - EN202003
H417 SQUASH

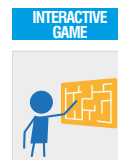

ORGANIZATION WITH QUALITY MANAGEMENT SYSTEM
ISO 9001:2015 CERTIFIED by
EuCI European Certification Institute LTD
Certificate N.: GOTT253201932

ORGANIZATION WITH ENVIRONMENTAL MANAGEMENT SYSTEM
ISO 14001:2015 CERTIFIED by
EuCI European Certification Institute LTD
Certificate No: GOTT2532E1901



CATALOG COLLECTION	LET'S PLAY TOGETHER
DIMENSIONS (L x W x H) in cm	65 x 85 x 215
MAXIMUM CFH	-
IMPACT ATTENUATING SURFACE	min. 16,00 m ² - MAX 16,00 m ²
SUGGESTED AGE OF USE	3+
COMPOSITION	Aluminium support poles in 90x90 mm; shaped pipe in rotational PTE with connecting panels and board in HDPE plate, 19 mm thick.

SECURITY AREA

← 365 →

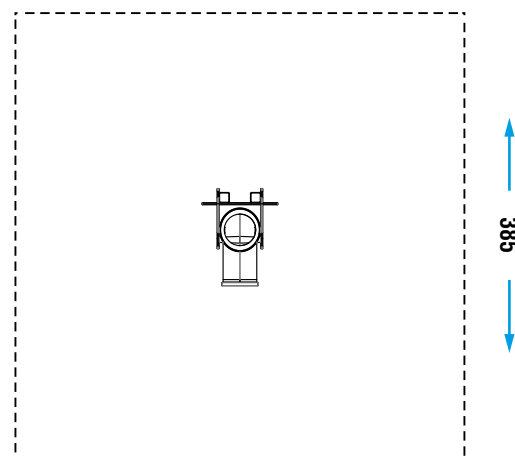

Make a proper security surface according to CFH. Periodic maintenance is mandatory, following manual supplied to customer.