

PRODUCT SHEET  
REV 2.1 - EN202003  
**6043 AMAZON**



ORGANIZATION WITH QUALITY MANAGEMENT SYSTEM  
ISO 9001:2015 CERTIFIED by  
EuCI European Certification Institute LTD  
Certificate N.: GOTT25201932

ORGANIZATION WITH ENVIRONMENTAL MANAGEMENT SYSTEM  
ISO 14001:2015 CERTIFIED by  
EuCI European Certification Institute LTD  
Certificate No: GOTT2520E1901



INTERACTIVE  
GAME



WALK/BALANCE



CLIMBING



SLIDING



|                                     |   |
|-------------------------------------|---|
| <b>CATALOG COLLECTION</b>           | FUN COLLECTION  |
| <b>DIMENSIONS (L x W x H) in cm</b> | 560 x 345 x 320   |
| <b>MAXIMUM CFH</b>                  | 125   |
| <b>IMPACT ATTENUATING SURFACE</b>   | min. 48,50 m <sup>2</sup> - MAX 55,25 m <sup>2</sup>  |
| <b>SUGGESTED AGE OF USE</b>         | 3 +   |
| <b>COMPOSITION</b>                  | <ul style="list-style-type: none"> <li>- n°9 timber or aluminium poles 9x9cm</li> <li>- n°2 timber or aluminium decks</li> <li>- n°1 gable roofs</li> <li>- n°3 rotating mold PTE guardpanels</li> <li>- n°1 rotating mold PTE climbing</li> <li>- n°3 HDPE sheet crossbars</li> <li>- n°1 metal playpanel</li> <li>- n°1 curved bridge</li> <li>- n°2 modular slides with HDPE crossbar</li> <li>- n°1 HDPE sheet flower decoration</li> </ul> |

SECURITY AREA

645

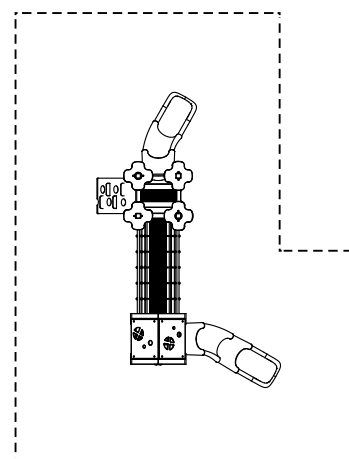

*Make a proper security surface according to CFH. Periodic maintenance is mandatory, following manual supplied to customer.*