

PRODUCT SHEET  
REV 2.1 - EN202003  
**4309 DOINA**



ORGANIZATION WITH QUALITY MANAGEMENT SYSTEM  
ISO 9001:2015 CERTIFIED by  
EuCI European Certification Institute LTD  
Certificate N.: GOTT253201932

ORGANIZATION WITH ENVIRONMENTAL MANAGEMENT SYSTEM  
ISO 14001:2015 CERTIFIED by  
EuCI European Certification Institute LTD  
Certificate No: GOTT2532E1801



SLIDING



<b>CATALOG COLLECTION</b>	PLAYGROUND ESSENTIALS
<b>DIMENSIONS (L x W x H) in cm</b>	275 x 85 x 245
<b>MAXIMUM CFH</b>	90
<b>IMPACT ATTENUATING SURFACE</b>	min. 24,00 m <sup>2</sup> - MAX 24,00 m <sup>2</sup>
<b>SUGGESTED AGE OF USE</b>	2+
<b>COMPOSITION</b>	<ul style="list-style-type: none"> <li>- n°6 octagonal profile aluminium structural poles</li> <li>- n°1 powder coated aluminium treadplate deck</li> <li>- n°2 guardpanel in HDPE sheet</li> <li>- n°1 aluminium stair</li> <li>- n°1 metal crossbar</li> <li>- n°1 rotating mold PTE modular slide</li> <li>- n°1 HDPE sheet decoration</li> </ul>

SECURITY AREA

385

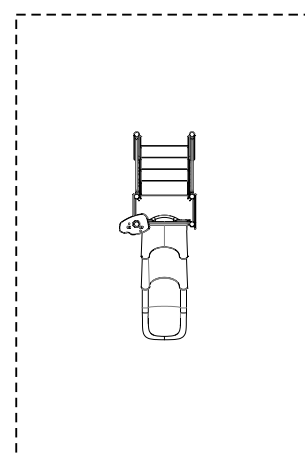

575

Make a proper security surface according to CFH. Periodic maintenance is mandatory, following manual supplied to customer.