

SCHEDA PRODOTTO
REV 1.1 - IT202003
4001 BIZZY



ORGANIZATION WITH QUALITY MANAGEMENT SYSTEM
ISO 9001:2015 CERTIFIED by
EuCI European Certification Institute LTD
Certificate N.: GOTT253201932

ORGANIZATION WITH ENVIRONMENTAL MANAGEMENT SYSTEM
ISO 14001:2015 CERTIFIED by
EuCI European Certification Institute LTD
Certificate No: GOTT2532E1801



INCONTRO E
GIOCO SIMBOLICO



GIOCO INTERATTIVO

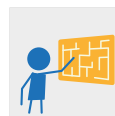

SCIVOLARE



COLLEZIONE	TIKA LINE
DIMENSIONI (L x P x H) in cm	190 x 260 x 240
ALTEZZA CRITICA DI CADUTA	60
AREA MIN/MAX ANTITRAUMA	min. 25,50 m ² - MAX 27,50 m ²
ETÀ D'USO CONSIGLIATA	3 +

COMPOSIZIONE	<ul style="list-style-type: none"> - n°5 pali portanti in alluminio ottagonale - n°1 pedana in alluminio - n°1 tetto a due falde in lastra di HDPE - n°2 parapetti in metallo - n°1 scala in alluminio - n°1 scivolo modulare - n°3 pannelli gioco in lastra di HDPE - n°2 panchette in lastre di HDPE - n°1 tavolinetto in lastra di HDPE - n°1 decoro in lastra di HDPE
---------------------	---

AREA DI SICUREZZA

← 490 →

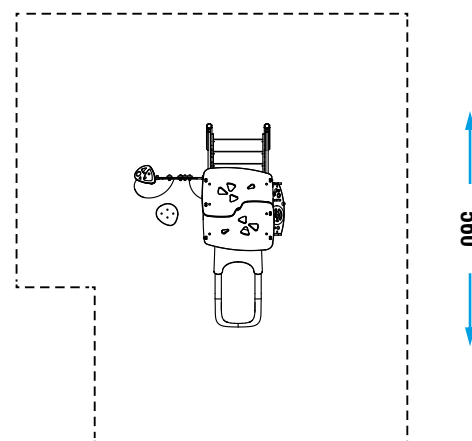

Realizzare un idoneo fondo antitrauma in funzione dell'altezza critica di caduta. Manutenzione periodica obbligatoria come da piano consegnato al cliente.